

Prisma DIN 69881

Prism DIN 69881 / Prisma DIN 69881

Katalog Nr.
Catalogue No. | Numéro de catalogue

8

WENDELtools
TECHNOLOGY YOU CAN TRUST

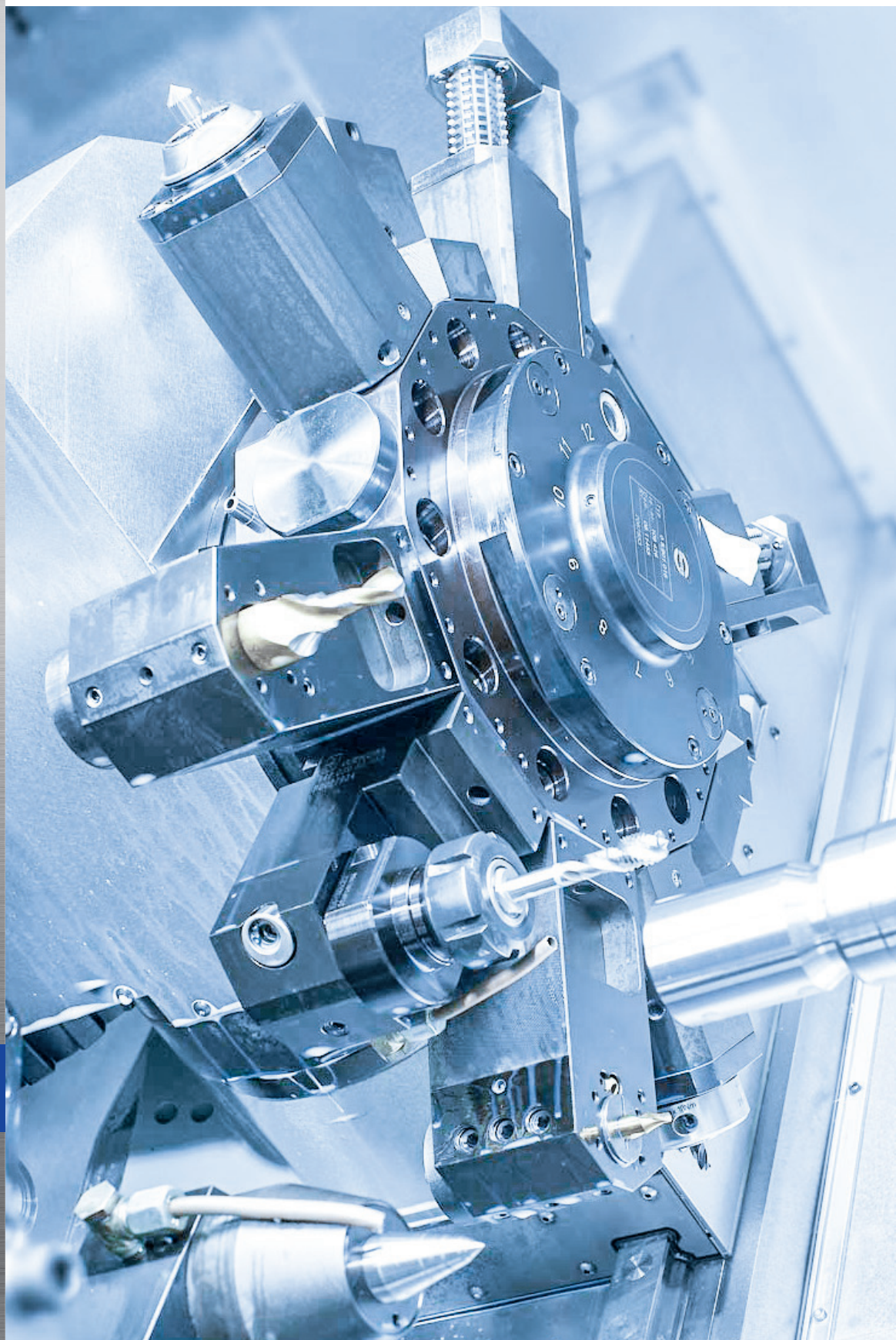

QUALITY MADE IN GERMANY

www.wendel-tools.de

Unsere Produkte erfüllen auch höchste Erwartungen

Was nutzt die beste Maschine, wenn das Werkzeug nicht mithalten kann?

Wir sind stolz darauf, unseren Kunden angetriebene Werkzeuge mit bemerkenswert geringen Toleranzen bieten zu können.

Hochpräzise, langlebige Präzisionswerkzeuge, Werkzeugsysteme und Mehrspindelköpfe für Drehzentren und Bearbeitungszentren. Ob mit oder ohne Antrieb, ob als Standardausführung oder als Sonderanfertigung.

Und damit es erst gar nicht hart auf hart kommt, werden bei uns alle Werkzeughalter einsatzgehärtet – und zwar komplett. Nicht nur alle Funktionsflächen, sondern sämtliche Oberflächen trotzen zuverlässig dem Verschleiß.

Hochwertige, robuste Werkzeug-Garanten für lange Werkzeugstandzeiten und eine exakte Produktion:

Auf der ganzen Welt arbeiten anspruchsvolle Unternehmen mit den Qualitätswerkzeugen von Wendel.

WENDELtools

TECHNOLOGY YOU CAN TRUST

WENDEL tools GmbH

Hofgarten 5
D-72160 Horb
Fon: +49 (0) 74 51 / 55 27 - 0
Fax: +49 (0) 74 51 / 55 27 - 27

Mail: info@wendel-tools.de



Winkel Bohr- und Fräsköpfe für Bearbeitungszentren Katalog BAZ – INFO



Modulares Werkzeugsystem HW – Wendel Katalog 9.180

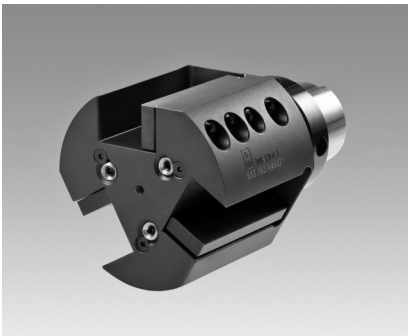

Modulares Werkzeugsystem HSK – DIN 69893 Katalog 9.650

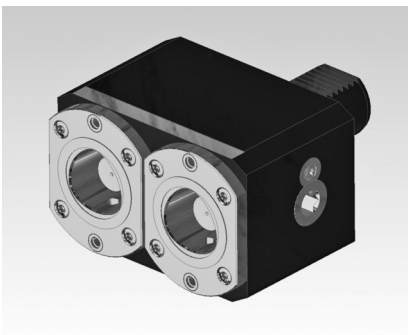

Modulares Werkzeugsystem Capto Katalog 9.750

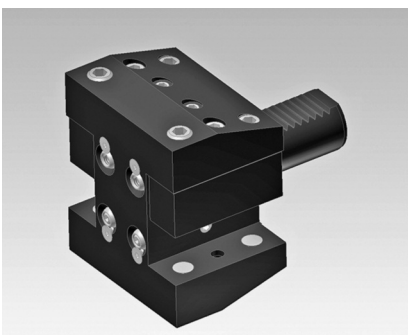

Werkzeughalter DIN 69880 Katalog 1 – 4



**Kataloge für angetriebene Werkzeuge
sind nach Antriebs- und Maschinentypen
unterteilt.**

**Sprechen Sie uns an, wir lassen Ihnen gerne
die entsprechenden Kataloge zukommen.**

Beispiele für Capto - Prismenwerkzeughalter nach DIN 69881

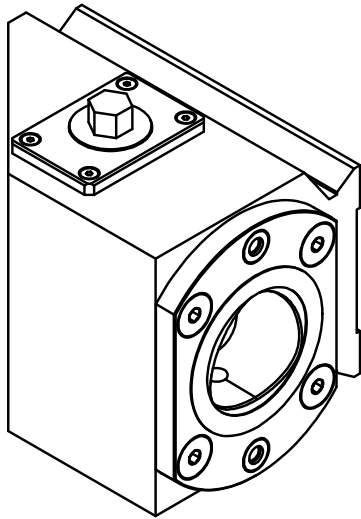

Prismen - Werkzeughalter
370.115-A5452
CAPTO - C8

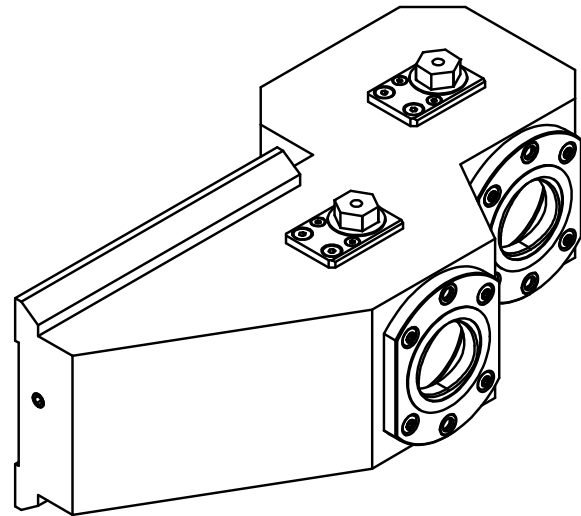

2-fach Prismen-Werkzeughalter
300.115-A5109
CAPTO - C5

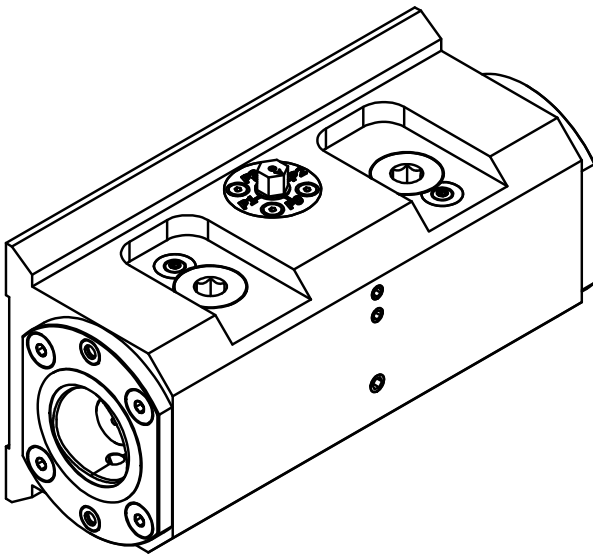

2-fach Prismen-Werkzeughalter
370.115-A5678
CAPTO - C5 + C6

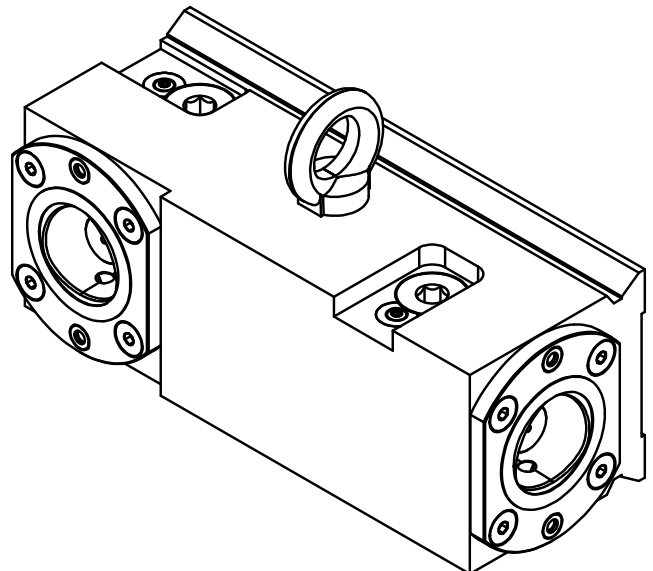

2-fach Prismen-Werkzeughalter
370.115-A5733
CAPTO - C6

weitere Sonderausführungen auf Anfrage

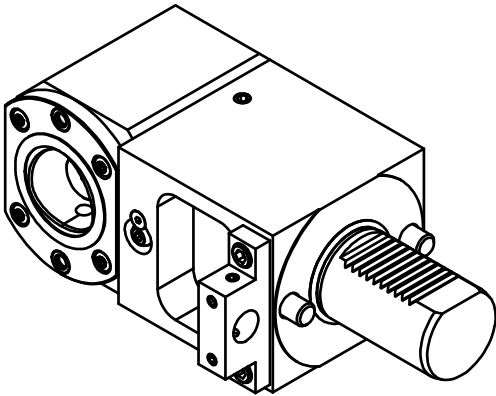
Beispiele für Werkzeuge mit CAPTO-Schnittstelle und CAPTO-Aufnahme

Capto - Werkzeughalter - VDI

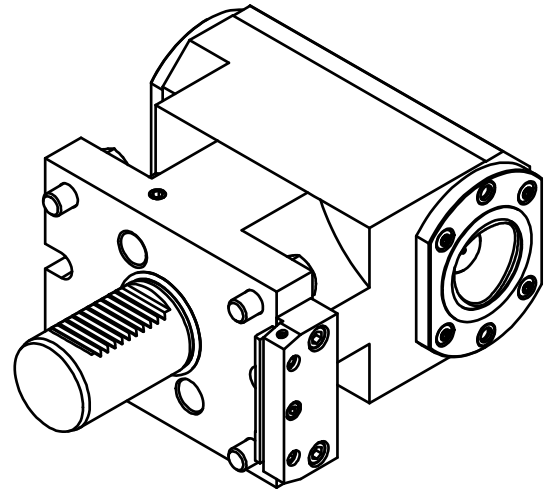

2-fach Capto - Werkzeughalter - VDI

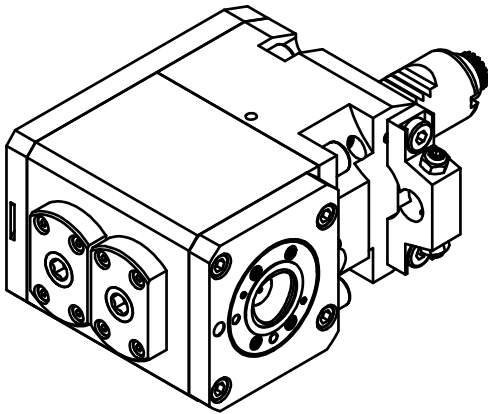

Doppel-Winkelfräskopf Capto C4

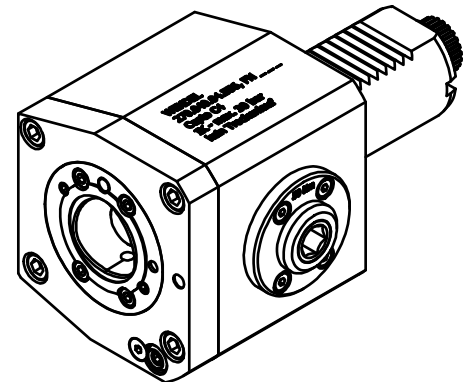

Axial - Fräskopf Capto C4

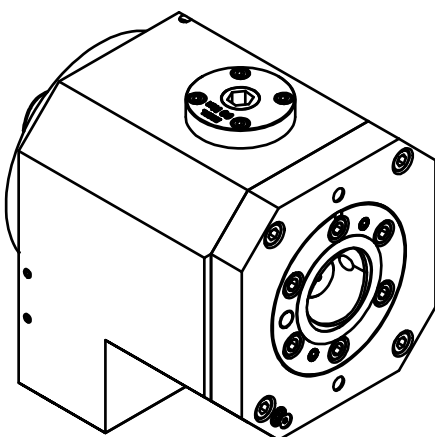

Axial - Fräskopf Capto C6

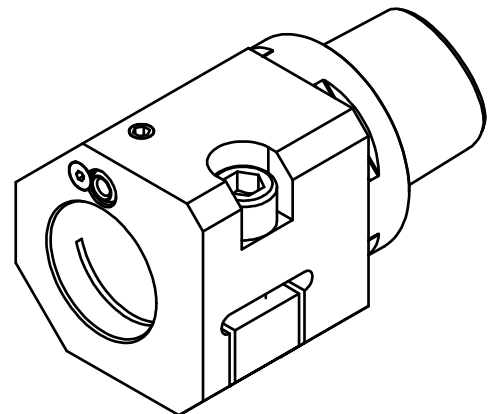

Capto - Bohrstangenaufnahme

CAPTO - Standardwerkzeuge siehe Katalog 9.750
Sonderausführungen auf Anfrage

Beispiele für Werkzeuge mit HSK-Schnittstelle und HSK-Aufnahme

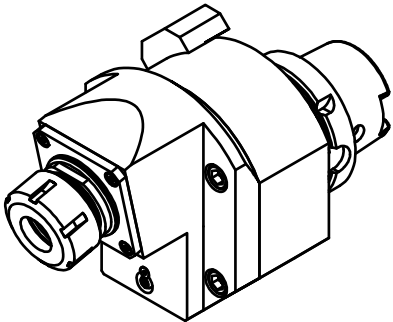

Winkel-Fräskopf für BAZ - HSK100A

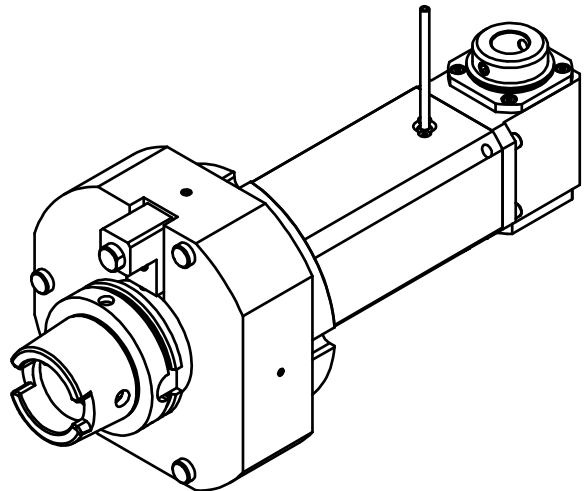

Winkel-Fräskopf für BAZ - HSK100A

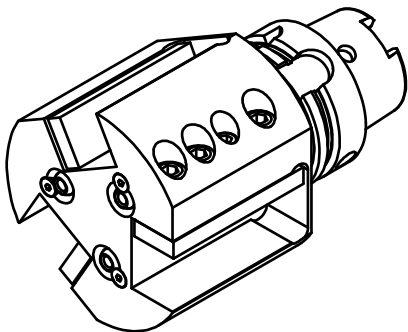

3-fach Werkzeughalter - HSK63A

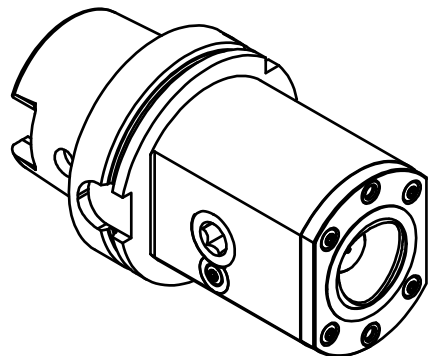

Capto - Werkzeughalter - HSK100A

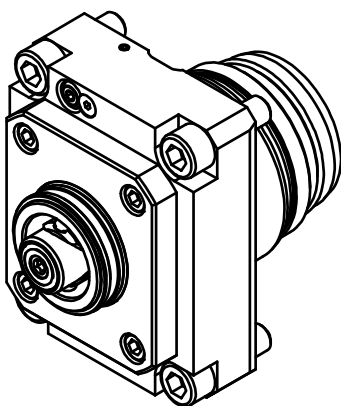

Axial - Fräskopf CDI - HSK50C

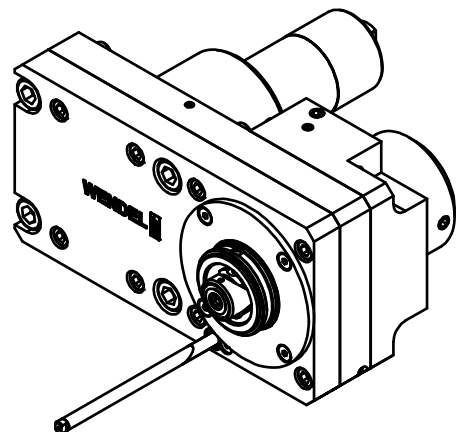

Desaxialer - Fräskopf CDI - HSK40C

HSK - Standardwerkzeuge siehe Katalog 9.650
Sonderausführungen auf Anfrage

Beispiele für Werkzeuge mit HW-Aufnahme

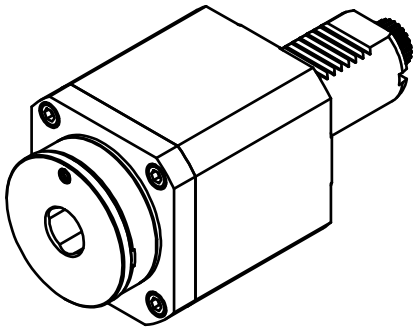

Axial-Fräskopf HW44 mit
HW-Einsatz - DIN 1835-B

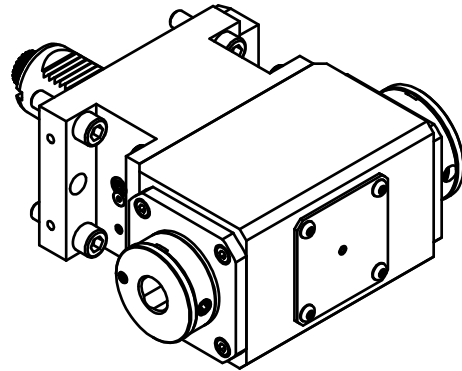

Doppel-Winkel-Fräskopf HW34/HW44
mit 2 HW-Einsätzen DIN 1835-B

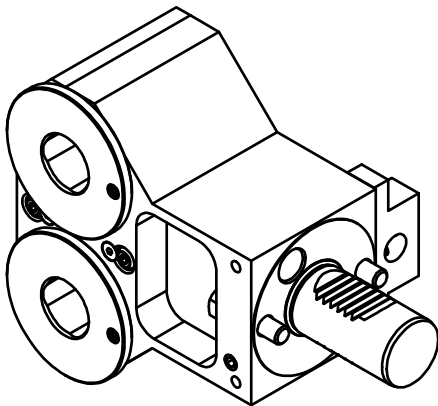

2-fach Werkzeughalter - HW44
mit 2 HW-Einsätzen - DIN 1835-B

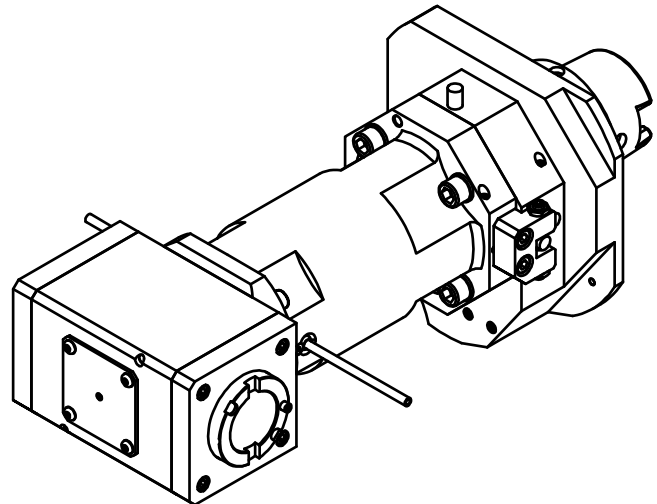

Doppel-Winkel-Fräskopf HW44
für BAZ mit HSK-100A

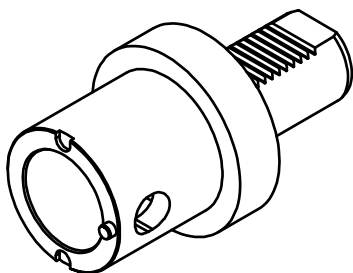

Einstelladapter VDI40 - HW44

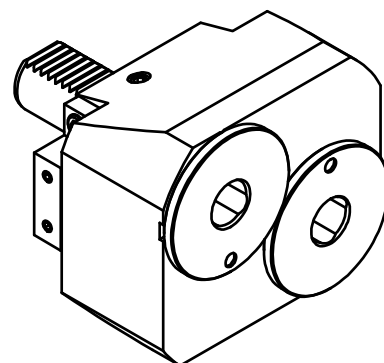

2-fach Werkzeughalter - HW44
mit 2 HW-Einsätzen - DIN 1835-B



HW - Standardwerkzeuge siehe Katalog 9.180
Sonderausführungen auf Anfrage

Das HW-System ist patentrechtlich geschützt

Prismenhalter NG 56 - NG 140 DIN 69881 (VDI 3425 BL. 3)

Dove tail tool holders

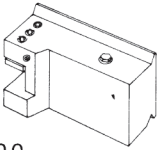
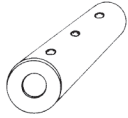
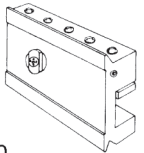
Ajustement prismatique

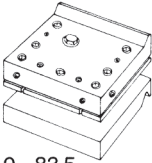
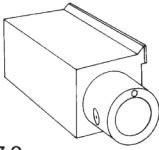
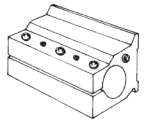
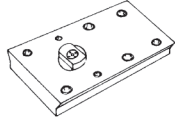
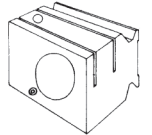
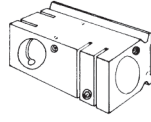
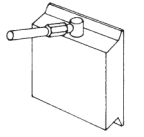
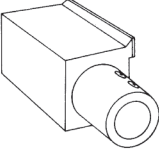
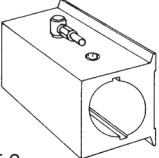
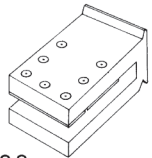
<p>NC 301</p>  <p>Seite, Page 80.0</p>	<p>Radial-Werkzeughalter <i>Radial Toolholder</i> Porte-outil, radial</p>	<p>NC 314</p>  <p>Seite, Page 86.0</p>	<p>Reduzierbüchse <i>Reduction Bushes</i> Douille de Réduction</p>
<p>NC 302</p>  <p>Seite, Page 81.0</p>	<p>Axial-Werkzeughalter <i>Axial Toolholder</i> Porte-outil, axial à gauche, à droite</p>	<p>NC 315</p>  <p>Seite, Page 86.5</p>	<p>Reduzierhülse MK 1-6 <i>Reduction Bushes</i> Douille de Réduction</p>
<p>NC 343 NC 304 NC 345</p>  <p>Seite, Page 82.0 - 83.5</p>	<p>Mehrfach-Werkzeughalter breit, schmal <i>Multi Toolholder</i> <i>wide, narrow</i> Porte-outil, multiple large etroit</p>	<p>NC 316 Form WN</p>  <p>Seite, Page 87.0</p>	<p>ABS - NC - Aufnahme - Lizenz Komet -</p>
<p>NC 306 NC 307 NC 308 NC 309</p>  <p>Seite, Page 84.0 - 86.6</p>	<p>Bohrstangenhalter lang, kurz <i>Boring Bar Holder</i> <i>long Short</i> Porte-outil, pour Barre d'Alésage long, court</p>	<p>NC 320 NC 321</p>  <p>Seite, Page 87.4 - 87.6</p>	<p>Werkzeughalterplatte breit schmal <i>Toolholder Plate</i> <i>wide, narrow</i> Plaque de Porte-outil, large, étroit</p>
<p>NC 310</p>  <p>Seite, Page 85.0</p>	<p>Bohrstangenhalter radial <i>Boring Bar Holder</i> <i>radial</i> Porte-outil pour Barre d'Alésage</p>	<p>NC 325</p>  <p>Seite, Page 88.0</p>	<p>Doppel- Bohrstangenhalter <i>Double Boring</i> <i>Bar Holder</i> Porte-outil pour Barre d'Alésage, Double</p>
<p>NC 311</p>  <p>Seite, Page 85.4</p>	<p>Kühlmittelverteiler <i>Coolant Adaptor</i> Distributeur de Lubrification</p>	<p>NC 327 NC 329</p>  <p>Seite, Page 88.4 - 88.7</p>	<p>Wendeplattenbohreraufnahme, zyl. mit Innenkühlung <i>"U" Drill Holder with</i> <i>internal coolant channel</i> Porte Foret pour Foret à Plaquettes</p>
<p>NC 313</p>  <p>Seite, Page 85.6</p>	<p>Stellhülseaufnahme kurz <i>Setting Sleeve Holder</i> Porte Douilles de Réglage</p>	<p>NC 330</p>  <p>Seite, Page 88.8</p>	<p>Mehrfach-Werkzeughalter, lang <i>Multi Toolholder,</i> <i>long</i> Porte-outil, multiple large long</p>

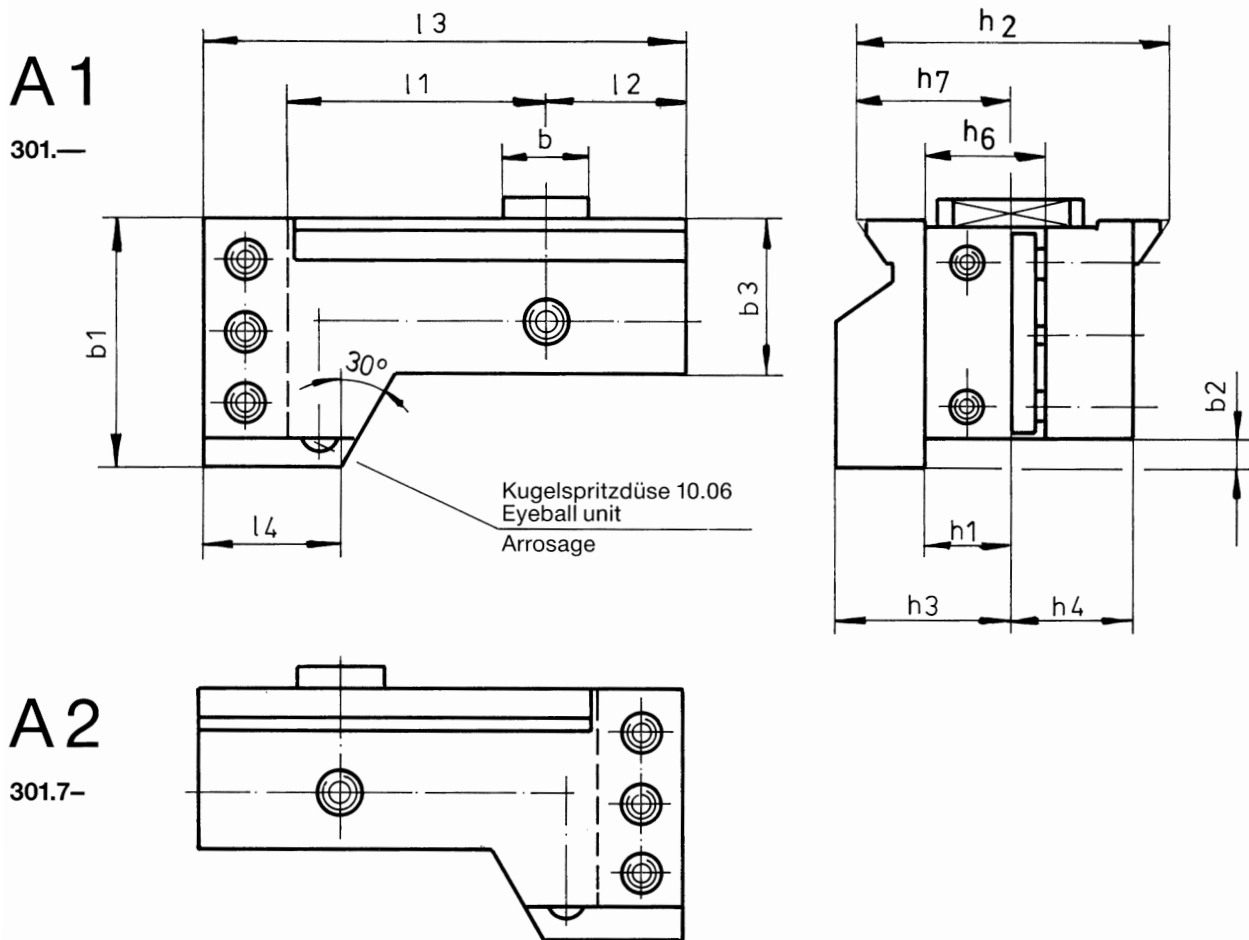

Prisma															Bestell-Nummer Part-No. Codification
	h_2	Form	b	b_1	b_2	b_3	h_1 -0,1	h_3	h_4	h_6 max.	h_7 $\pm 0,05$	l_1 0+0,5	l_2	l_3	
56	A 1	16	50	6	32	16	40	19	22	28	49	31	94	34	301.056.16
56	A 2	16	50	6	32	16	40	19	22	28	49	31	94	34	301.756.16
72	A 1	20	63	6	40	20	43	27	29	36	49	39	110	45	301.072.20
72	A 2	20	63	6	40	20	43	27	29	36	49	39	110	45	301.772.20
90	A 1	25	72	9	40	25	50	35,5	34	45	73	39	138	45	301.090.25
90	A 2	25	72	9	40	25	50	35,5	34	45	73	39	138	45	301.790.25
115	A 1	25	85	9	50	32	60	40	41	57,5	112	49	191	50	301.115.32
115	A 2	25	85	9	50	32	60	40	41	57,5	112	49	191	50	301.715.32
140	A 1	25	110	12	60	40	78	57,5	53	70	115	59	209	55	301.140.40
140	A 2	25	110	12	60	40	78	57,5	53	70	115	59	209	55	301.740.40

Kühlschmierstoffzuführung durch Kugelspritzdüse, Anschluß für drehbare Rohrverschraubung (soweit techn. mögl.)
Feed of coolant by means of a ball spraying nozzle; with connection for revolving screwed pipe coupling
(as far as it is technically possible)
Alimentation d'agent réfrigérant par un gicleur en forme de boule; avec un raccord pour des accouplements des tuyaux tournants (si possible technologiquement)

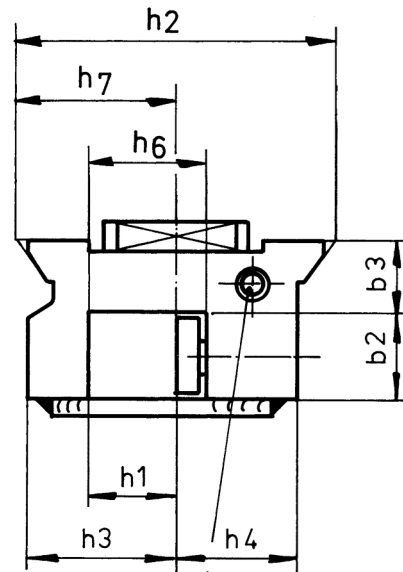
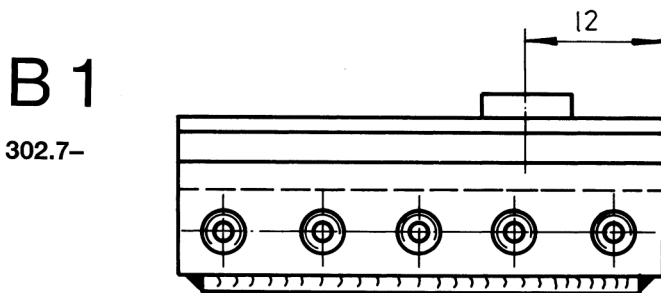
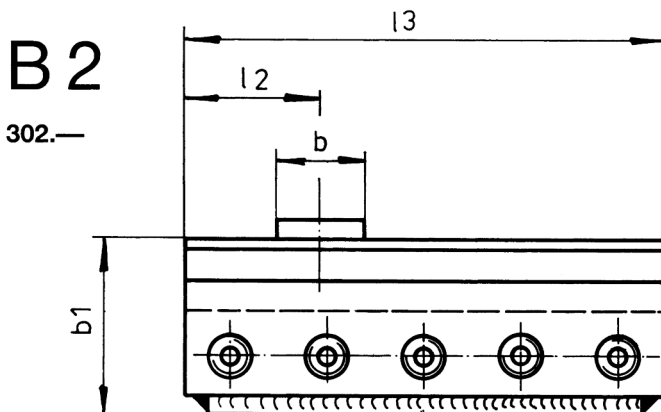

Beidseitig
Kugelspritzdüse 10.06
Eyeball unit
Arrosage

Prisma														Bestell-Nummer Part-No. Codification
	h_2	Form	b	b_1	b_2	b_3 +0,5	h_1 -0,1	h_3	h_4	h_6 max	h_7 $\pm 0,05$	l_2	l_3	
56	B 2	16	39	20	16	16	26	19		22	28	31	94	302.056.16
56	B 1	16	39	20	16	16	26	19		22	28	31	94	302.756.16
72	B 2	20	47	26	16	20	34	27		29	36	39	110	302.072.20
72	B 1	20	47	26	16	20	34	27		29	36	39	110	302.772.20
90	B 2	25	49	26	18	25	42,5	35,5		34	45	39	118	302.090.25
90	B 1	25	49	26	18	25	42,5	35,5		34	45	39	118	302.790.25
115	B 2	25	56	33	18	32	55	40		41	57,5	49	123	302.115.32
115	B 1	25	56	33	18	32	55	40		41	57,5	49	123	302.715.32
140	B 2	25	67	42	20	40	67,5	57,5		53	70	59	160	302.140.40
140	B 1	25	67	42	20	40	67,5	57,5		53	70	59	160	302.740.40

Kühlschmierstoffzuführung durch Kugelspritzdüse, Anschluß für drehbare Rohrverschraubung (soweit techn. mögl.)
Feed of coolant by means of a ball spraying nozzle; with connection for revolving screwed pipe coupling
(as far as it is technically possible)
Alimentation d'agent réfrigérant par un gicleur en forme de boule; avec un raccord pour des accouplements des tuyaux tournants (si possible technologiquement)

C 2

343.-

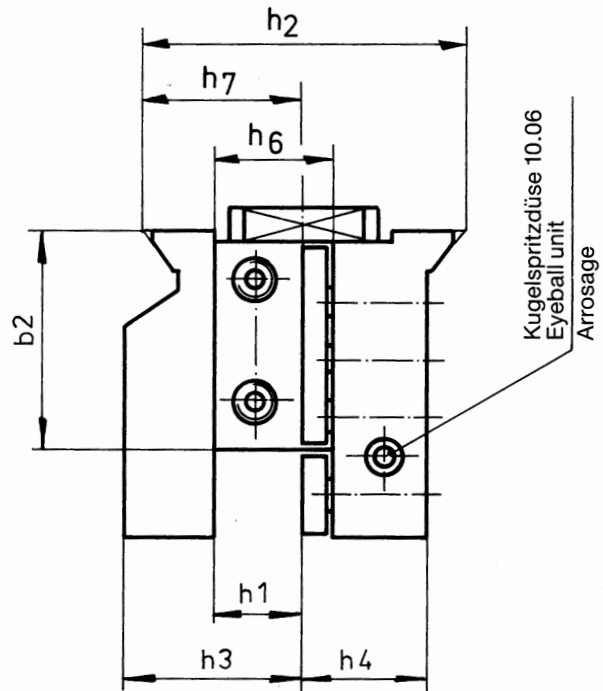
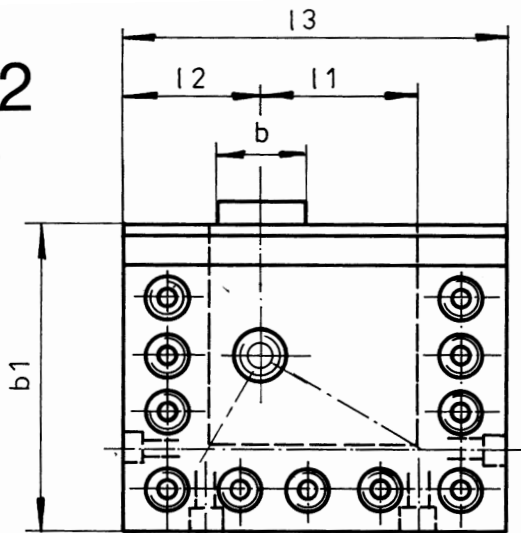

C 1

343.7

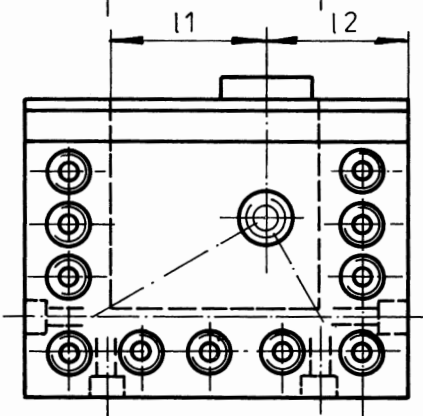

Ausführung nur bei $h_2 = 72$

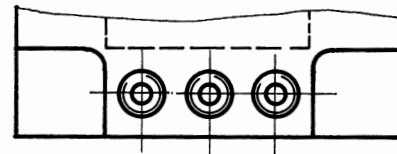

Prisma														Bestell-Nummer Part-No. Codification
h_2	Form	b	b_1	b_2 +0,5	h_1 -0,1	h_3	h_4	h_6 max	h_7 $\pm 0,05$	l_1 +0,5	l_2	l_3		
56	C 2	16	60	46	16	40	19	22	28	39	31	84	343.056.16	
56	C 1	16	60	46	16	40	19	22	28	39	31	84	343.756.16	
72	C 2	20	81	59	20	43	27	29	36	37	39	98	343.072.20	
72	C 1	20	81	59	20	43	27	29	36	37	39	98	343.772.20	
90	C 2	25	88	62	25	50	35,5	34	45	43	39	108	343.090.25	
90	C 1	25	88	62	25	50	35,5	34	45	43	39	108	343.790.25	
115	C 2	25	94	68	32	60	40	41	57,5	43	49	118	343.115.32	
115	C 1	25	94	68	32	60	40	41	57,5	43	49	118	343.715.32	
140	C 2	25	115	83	40	78	57,5	53	70	53	59	144	343.140.40	
140	C 1	25	115	83	40	78	57,5	53	70	53	59	144	343.740.40	

Kühlschmierstoffzuführung durch Kugelspritzdüse, Anschluß für drehbare Rohrverschraubung (soweit techn. mögl.)
Feed of coolant by means of a ball spraying nozzle; with connection for revolving screwed pipe coupling
(as far as it is technically possible)
Alimentation d'agent réfrigérant par un gicleur en forme de boule; avec un raccord pour des accouplements des tuyaux tournants (si possible technologiquement)

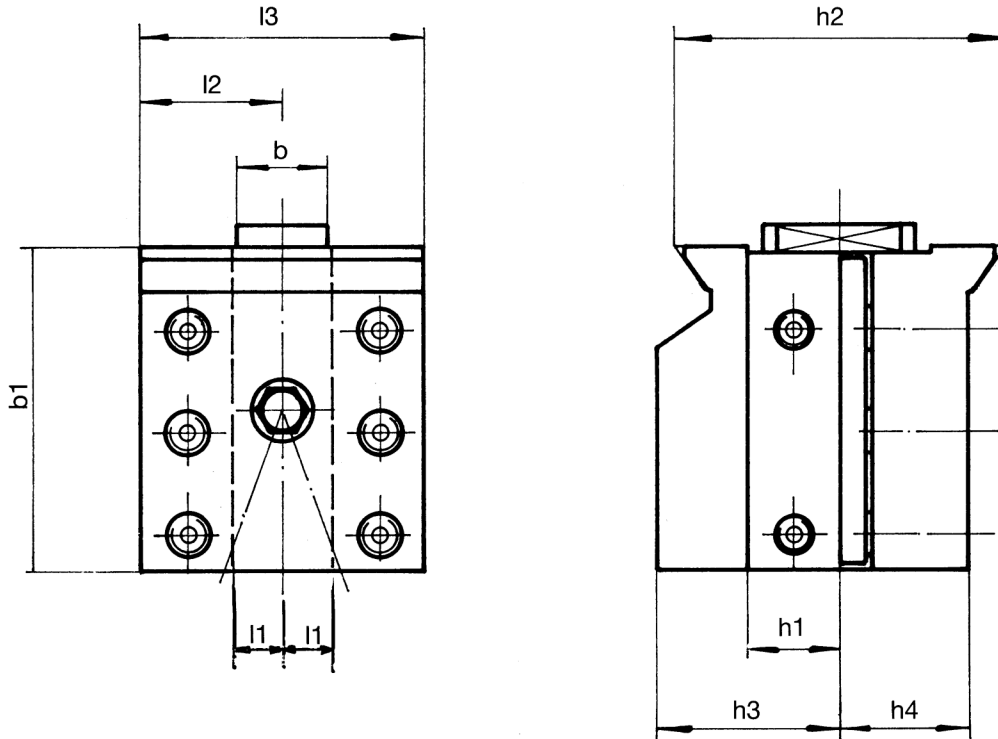

Prisma										Bestell-Nummer Part-No. Codification	
h₂	h ₁	h ₃	h ₄	b	b ₁	l ₁ +0,5	l ₂	l ₃			
72	20	43	27	20	81	17	39	78			304.072.20
90	25	50	35,5	25	88	13	39	78			304.090.25
115	32	60	40	25	94	23	49	98			304.115.32
140	40	78	57,5	25	115	27	59	118			304.140.40

Werkzeugkühlung: Kugelspritzdüse
Coolant: Eyeball unit
Refroidissement: Arrosage

Anschluß für drehbare Rohrverschraubung (soweit techn. möglich)
Connection for swilling pipe (where techn. possible)
Raccord pour tuyau raccordé par vis (autant que possible technique)

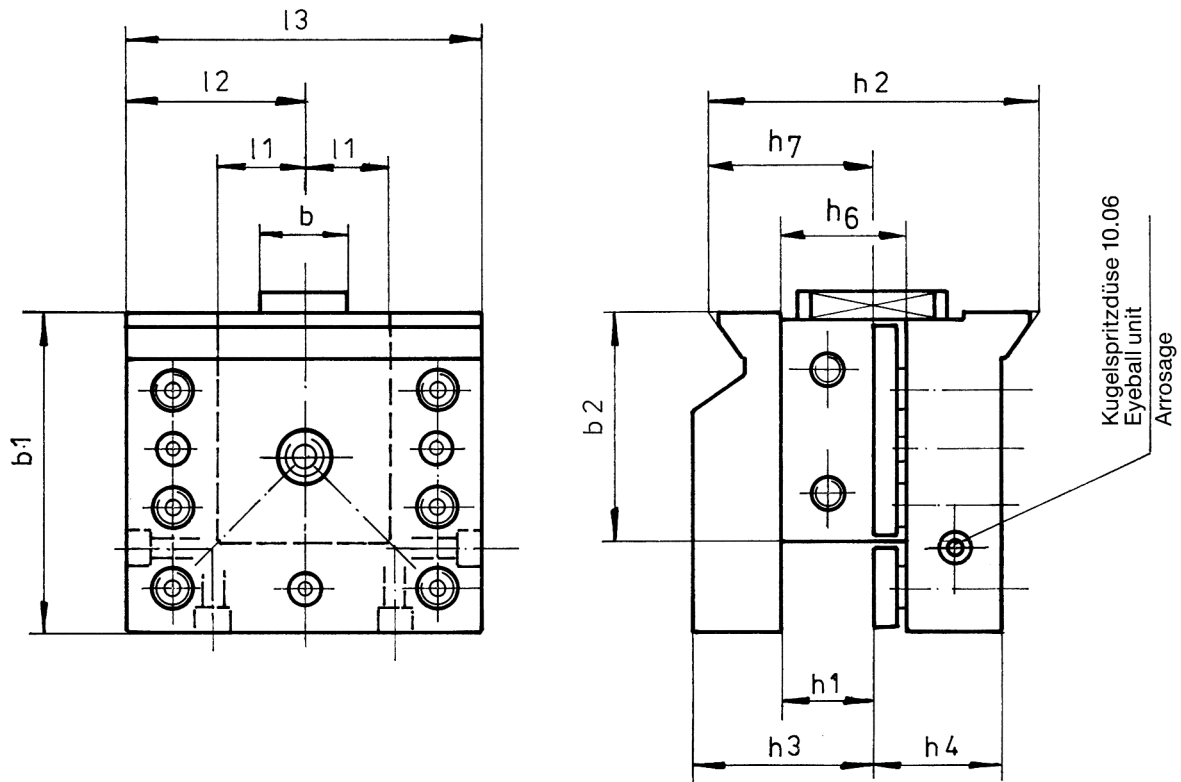

Prisma												Bestell-Nummer Part-No. Codification
h_2	b	b_1	b_2 +0,5	h_1 -0,1	h_3	h_4	h_6 max	h_7 $\pm 0,05$	l_1 +0,5	l_2	l_3	
56	16	60	46	16	40	19	22	28	17	31	62	345.056.16
72	20	81	59	20	43	27	29	36	17	39	78	345.072.20
90	25	88	62	25	50	35,5	34	45	23	49	98	345.090.25
115	25	94	68	32	60	40	41	57,5	23	49	98	345.115.32
140	25	115	83	40	78	57,5	53	70	27	59	118	345.140.40

Kühlschmierstoffzuführung durch Kugelspritzdüse, Anschluß für drehbare Rohrverschraubung (soweit techn. mögl.)
Feed of coolant by means of a ball spraying nozzle; with connection for revolving screwed pipe coupling
(as far as it is technically possible)
Alimentation d'agent réfrigérant par un gicleur en forme de boule; avec un raccord pour des accouplements des tuyaux tournants (si possible technologiquement)

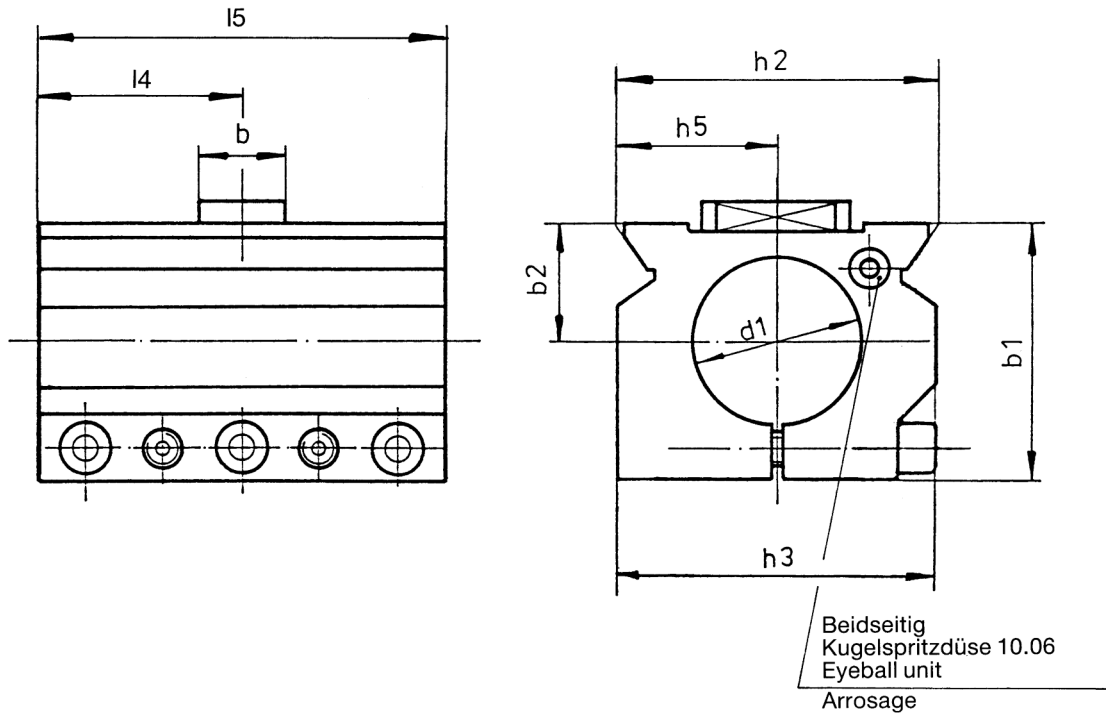

Prisma	d_1		b	b_1	b_2		h_3	h_5		l_4	l_5			Bestell-Nummer Part-No. Codification
h_2	h_7													
56	32		16	65	30		56	28		59	118			306.056.32
56	40		16	65	30		56	28		59	118			307.056.40
72	40		20	76	35		72	36		75	150			306.072.40
72	50		20	76	35		72	36		75	150			307.072.50
90	50		25	94	45		90	45		99	198			306.090.50
90	60		25	94	45		90	45		99	198			307.090.60
115	50		25	94	45		93	57.5		99	198			306.115.50
115	60		25	94	45		93	57.5		99	198			306.115.60
115	80		25	115	55		115	57.5		99	198			307.115.80
140	80		25	125	60		115	70		119	238			306.140.80
140	100		25	145	70		140	70		119	238			307.140.10

Kühlschmierstoffzuführung durch Kugelspritzdüse, Anschluß für drehbare Rohrverschraubung (soweit techn. mögl.)
 Feed of coolant by means of a ball spraying nozzle; with connection for revolving screwed pipe coupling
 (as far as it is technically possible)
 Alimentation d'agent réfrigérant par un gicleur en forme de boule; avec un raccord pour des accouplements des tuyaux
 tournants (si possible technologiquement)

D 1

308.—

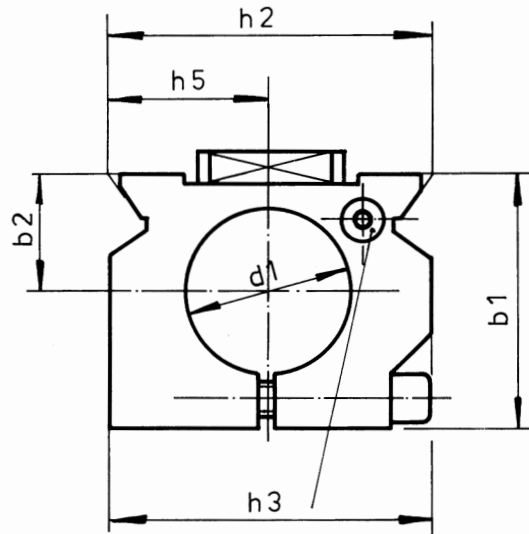
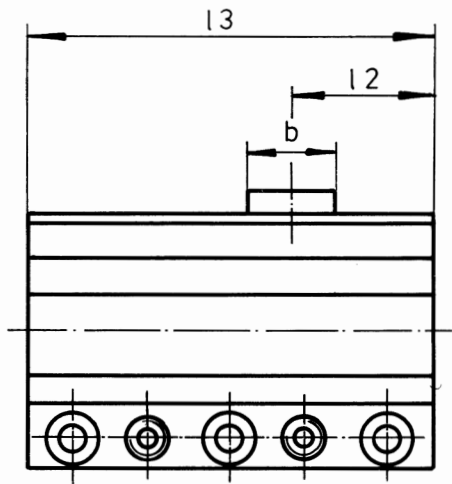

Beidseitig
Kugelspritzdüse 10.06
Eyeball unit
Arrosage

D 2

308.7-

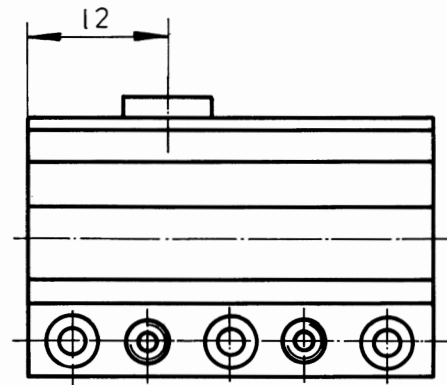

Prisma												Bestell-Nummer Part-No. Codification
h_2	Form	d_1 H_7	b	b_1	b_2	h_3	h_5	l_2	l_3			
56	D 1	32	16	65	30	56	28	31	94			308.056.32
56	D 2	32	16	65	30	56	28	31	94			308.756.32
72	D 1	40	20	76	35	72	36	39	110			308.072.40
72	D 2	40	20	76	35	72	36	39	110			308.772.40
90	D 1	50	25	94	45	90	45	39	138			308.090.50
90	D 2	50	25	94	45	90	45	39	138			308.790.50
115	D 1	60	25	94	45	93	57.5	49	148			308.115.60
115	D 2	60	25	94	45	93	57.5	49	148			308.715.60
140	D 1	80	25	125	60	115	70	59	178			308.140.80
140	D 2	80	25	125	60	115	70	59	178			308.740.80

Kühlschmierstoffzuführung durch Kugelspritzdüse, Anschluß für drehbare Rohrverschraubung (soweit techn. mögl.)
Feed of coolant by means of a ball spraying nozzle; with connection for revolving screwed pipe coupling
(as far as it is technically possible)
Alimentation d'agent réfrigérant par un gicleur en forme de boule; avec un raccord pour des accouplements des tuyaux tournants (si possible technologiquement)

D 1

309.—

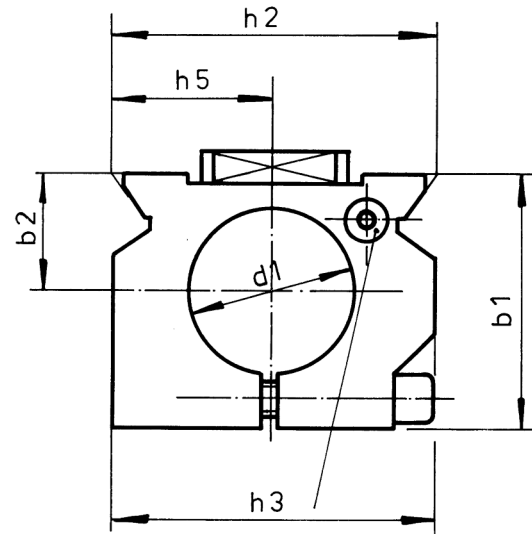
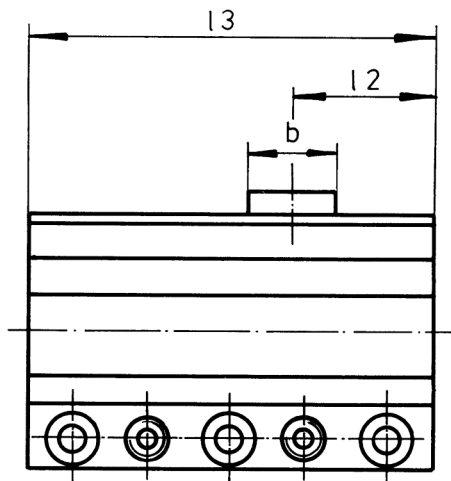

Beidseitig
Kugelspritzdüse 10.06
Eyeball unit
Arrosage

D 2

309.7-

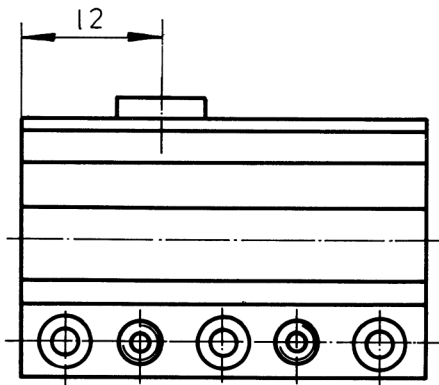

Prisma												Bestell-Nummer Part-No. Codification
	h ₂	Form	d ₁ H ₇	b	b ₁	b ₂		h ₃	h ₅	l ₂	l ₃	
	56	D 1	40	16	65	30		56	28	31	94	309.056.40
	56	D 2	40	16	65	30		56	28	31	94	309.756.40
	72	D 1	50	20	76	35		72	36	39	110	309.072.50
	72	D 2	50	20	76	35		72	36	39	110	309.772.50
	90	D 1	60	25	94	45		90	45	39	138	309.090.60
	90	D 2	60	25	94	45		90	45	39	138	309.790.60
	115	D 1	80	25	115	55		115	57.5	49	148	309.115.80
	115	D 2	80	25	115	55		115	57.5	49	148	309.715.80
	140	D 1	100	25	145	70		140	70	59	178	309.140.10
	140	D 2	100	25	145	70		140	70	59	178	309.740.10

Kühlschmierstoffzuführung durch Kugelspritzdüse, Anschluß für drehbare Rohrverschraubung (soweit techn. mögl.)
Feed of coolant by means of a ball spraying nozzle; with connection for revolving screwed pipe coupling
(as far as it is technically possible)

Alimentation d'agent réfrigérant par un gicleur en forme de boule; avec un raccord pour des accouplements des tuyaux tournants (si possible technologiquement)

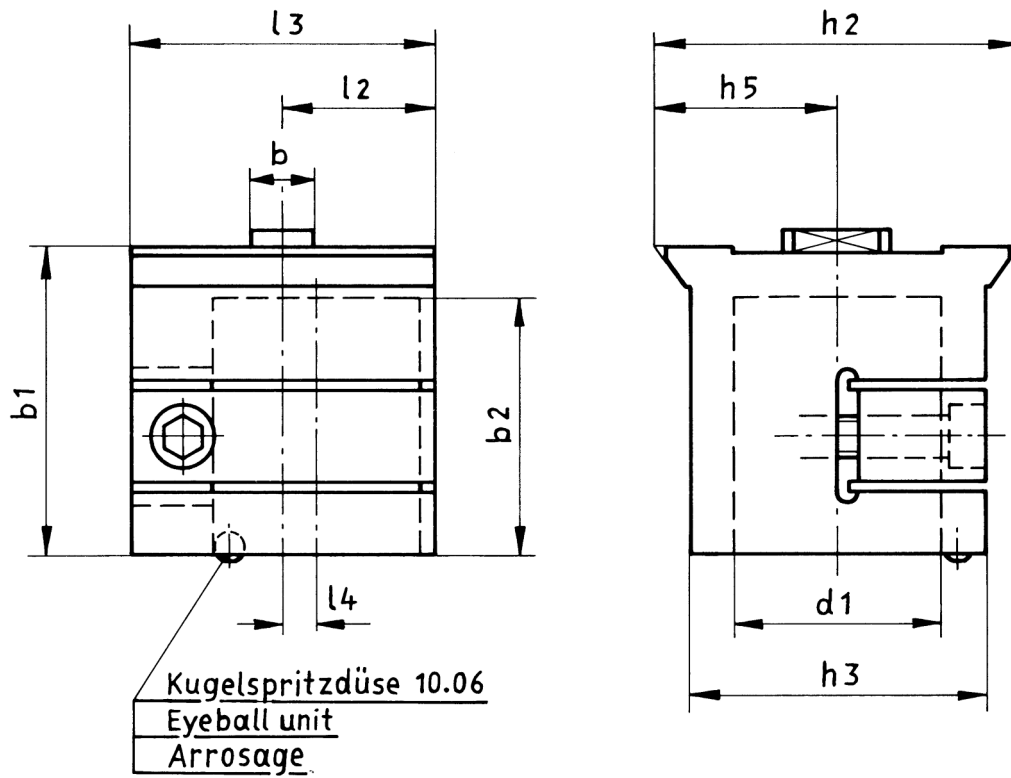

Prisma	d_1		b	b_1	b_2		h_3	h_5		l_2	l_3	l_4		Bestell-Nummer Part-No. Codification
h_2	H_7													
56	32		16	65	50		39	28		31	62	8		310.056.32
72	40		20	65	50		53	36		39	78	10		310.072.40
90	50		25	80	60		71	45		49	98	12,5		310.090.50
115	60		25	94	75		93	57,5		49	98	12,5		310.115.60
140	60		25	120	100		93	70		59	118	12,5		310.140.60
140	80		25	120	100		115	70		59	118	12,5		310.140.80

Nur für runde Werkzeuge, ohne Abflachung.

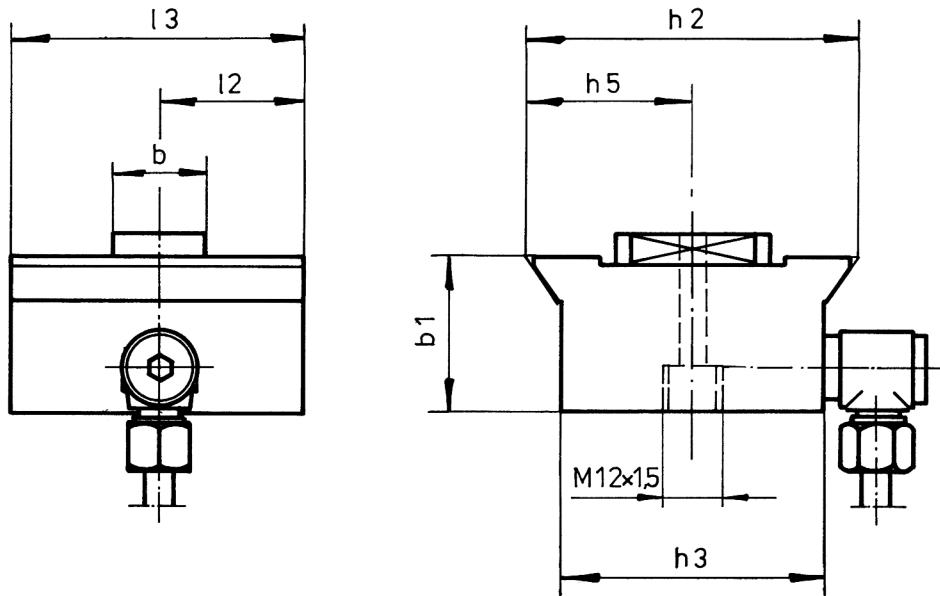

Prisma											Bestell-Nummer Part-No. Codification	
h₂	b	b ₁		h ₃	h ₅			l ₂	l ₃			
56	16	38		39	28			34	68			311.056.00
72	20	34		53	36			34	68			311.072.00
90	25	42		71	45			39	78			311.090.00
115	25	54		93	57,5			49	98			311.115.00
140	25	60		115	70			59	118			311.140.00

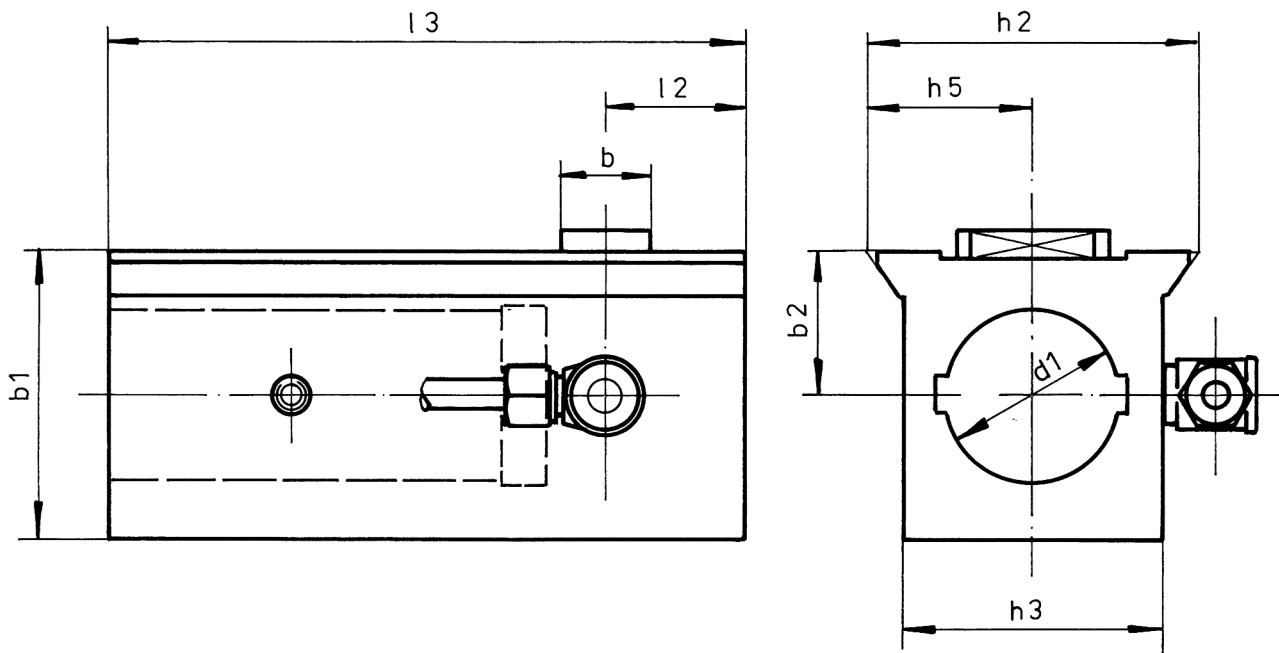

Prisma	d_1		b	b_1	b_2		h_3	h_5		l_2	l_3			Bestell-Nummer Part-No. Codification
h_2	H_7													
56	36		16	58	30		52	28		31	153			313.056.36
72	36		20	58	30		52	36		39	162			313.072.36
90	48		25	80	40		71	45		39	184			313.090.48
115	48		25	80	40		93	57,5		49	224			313.115.48
140	48		25	80	40		115	70		49	224			313.140.48

Werkzeugkühlung: Alle Stellhülsenahmen sind mit einer drehbaren Rohrverschraubung und einem Kühlmittelrohr ausgerüstet.

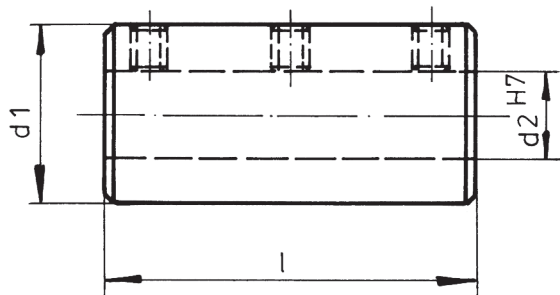

A

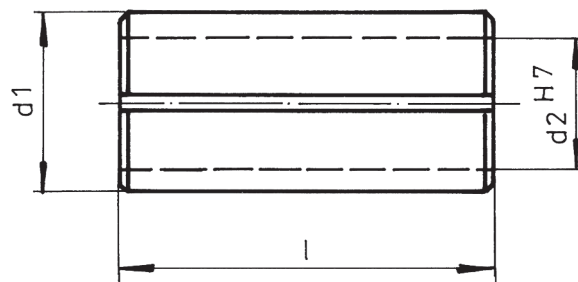

B

					Bestell-Nummer Part-No. Codification						Bestell-Nummer Part-No. Codification
d ₁	d ₂	l	Ausf.			d ₁	d ₂	l	Ausf.		
32	10	60	A		314.032.10	60	15	115	A		314.060.15
32	12	60	A		314.032.12	60	16	115	A		314.060.16
32	15	60	A		314.032.15	60	20	115	A		314.060.20
32	16	60	A		314.032.16	60	25	115	A		314.060.25
32	20	60	A		314.032.20	60	32	115	A		314.060.32
32	25	60	B		314.032.25	60	40	115	A		314.060.40
						60	50	115	B		314.060.50
40	10	80	A		314.040.10						
40	12	80	A		314.040.12	80	32	130	A		314.080.32
40	15	80	A		314.040.15	80	40	130	A		314.080.40
40	16	80	A		314.040.16	80	50	130	A		314.080.50
40	20	80	A		314.040.20	80	60	130	B		314.080.60
40	25	80	A		314.040.25						
40	32	80	B		314.040.32	100	50	170	A		314.100.50
						100	60	170	A		314.100.60
50	10	100	A		314.050.10	100	80	170	B		314.100.80
50	12	100	A		314.050.12						
50	15	100	A		314.050.15						
50	16	100	A		314.050.16						
50	20	100	A		314.050.20						
50	25	100	A		314.050.25						
50	32	100	A		314.050.32						
50	40	100	B		314.050.40						

Reduzierhülsen

Reduction bushes
Douille de reduction

NC 315
Form WN

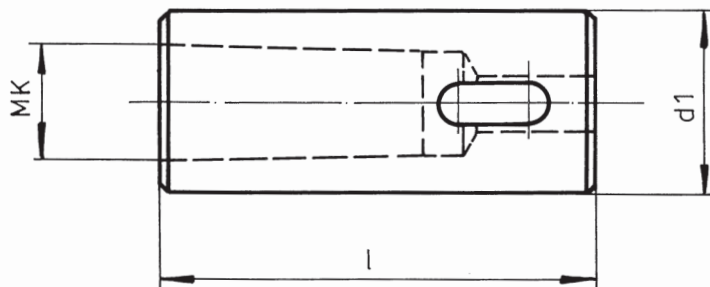

	d ₁	MK	l		Bestell-Nummer Part-No. Codification	d ₁	MK	l		Bestell-Nummer Part-No. Codification
	32	2	95		315.032.02					
	32	3	92		315.032.03	60	3	150		315.060.03
						60	4	150		315.060.04
	40	1	95		315.040.01	60	5	150		315.060.05
	40	2	95		315.040.02	80	3	150		315.080.03
	40	3	92		315.040.03	80	4	150		315.080.04
	40	4	118		315.040.04	80	5	150		315.080.05
	50	2	118		315.050.02	100	4	180		315.100.04
	50	3	118		315.050.03	100	5	180		315.100.05
	50	4	118		315.050.04	100	6	215		315.100.06

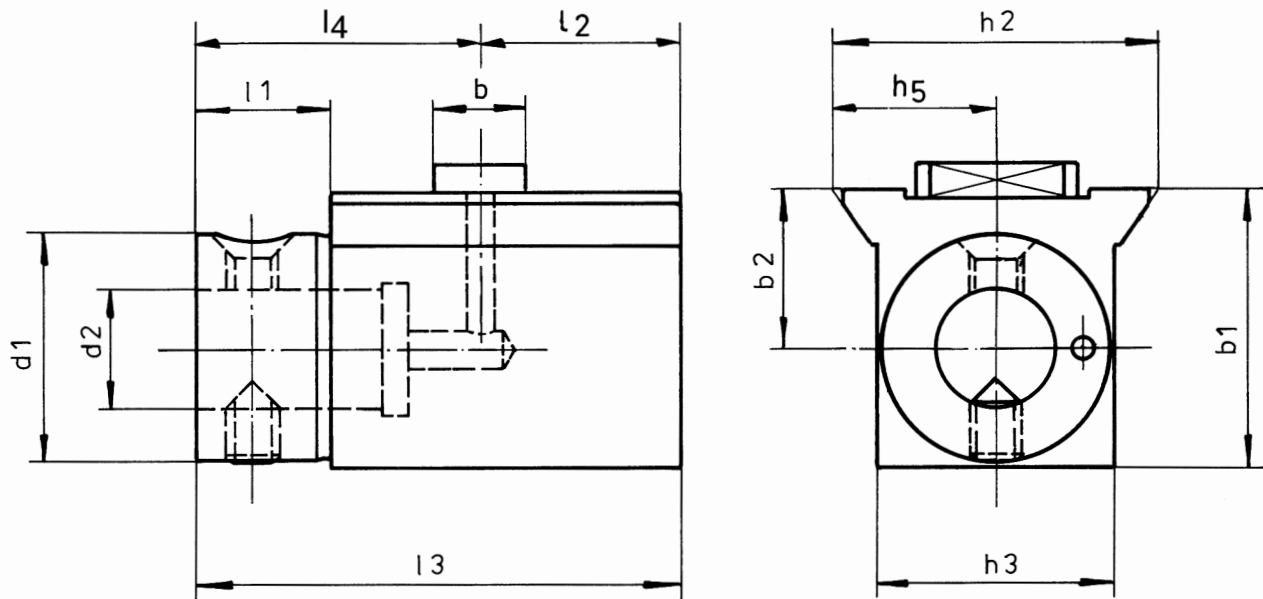

Prisma														Bestell-Nummer Part-No. Codification	
h₂	d ₁	d ₂		h ₃	h ₅	b	b ₁	b ₂		l ₁	l ₂	l ₃	l ₄		
72	50	28		53	36	20	62	35		30	39	110	71		316.072.50 ABS
90	50	28		71	45	25	72	45		30	39	138	99		316.090.50 ABS
90	63	34		71	45	25	78	45		40	39	138	99		316.090.63 ABS
115	50	28		93	57,5	25	72	45		30	49	148	99		316.115.50 ABS
115	63	34		93	57,5	25	78	45		40	49	148	99		316.115.63 ABS
115	80	46		93	57,5	25	88	45		45	49	148	99		316.115.80 ABS
140	50	28		115	70	25	88	60		30	59	178	119		316.140.50 ABS
140	63	34		115	70	25	95	60		40	59	178	119		316.140.63 ABS
140	80	46		115	70	25	102	60		45	59	178	119		316.140.80 ABS
140	100	56		115	70	25	112	60		60	59	178	119		316.140.10 ABS

Werkzeugkühlung: Durch die Aufnahmebohrung d₂.

Ausführung: Ganz einsatzgehärtet 58±2 HRC, Zugfestigkeit >900 N/mm², geschliffen und brüniert
 Execution: Totally hardened 58±2 HRC, tensile strength >N/mm², grinded and browning antirust treatment
 Exécution: Complètement trempé 58±2 HRC, résistance à la traction >900 N/mm², meulé et bruni

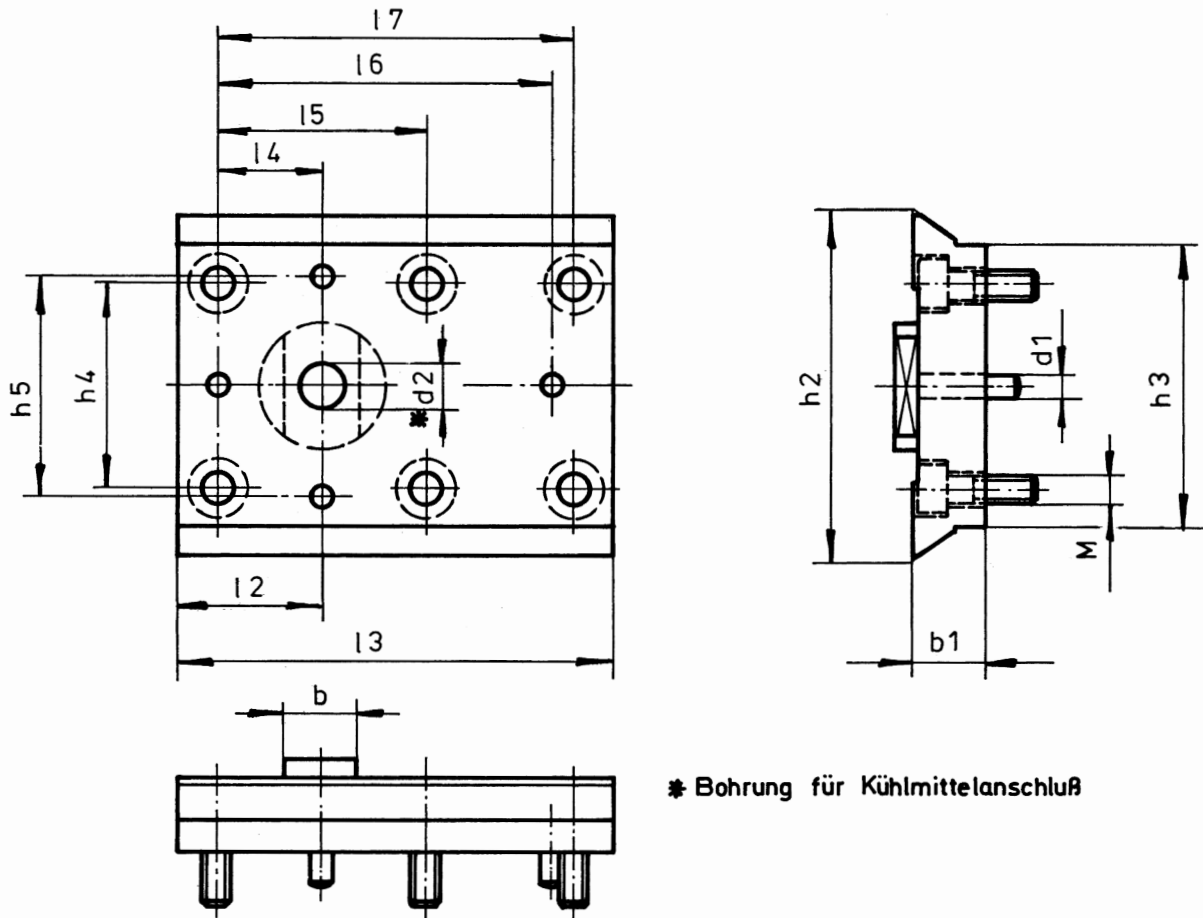

Prisma															Bestell-Nummer Part-No. Codification
h_2	d_1	d_2	b	b_1	h_3	h_4	h_5	l_2	l_3	l_4	l_5	l_6	l_7	M	
72	6	13	20	20	53	30	40	39	98	25	-	70	70	M 8	320.072.00
90	8	16	25	25	71	55	55	39	115	25	50	87	87	M 10	320.090.00
115	8	16	25	25	93	70	70	49	148	35	70	115	120	M 10	320.115.00
140	10	16	25	35	115	90	90	59	200	45	90	172	172	M 12	320.140.00

Ausführung: Ganz einsatzgehärtet 58 ± 2 HRC, Zugfestigkeit $> 900 \text{ N/mm}^2$, geschliffen und brüniert
 Execution: Totally hardened 58 ± 2 HRC, tensile strength $> \text{N/mm}^2$, grinded and browning antirust treatment
 Exécution: Complètement trempé 58 ± 2 HRC, résistance à la traction $> 900 \text{ N/mm}^2$, meulé et bruni

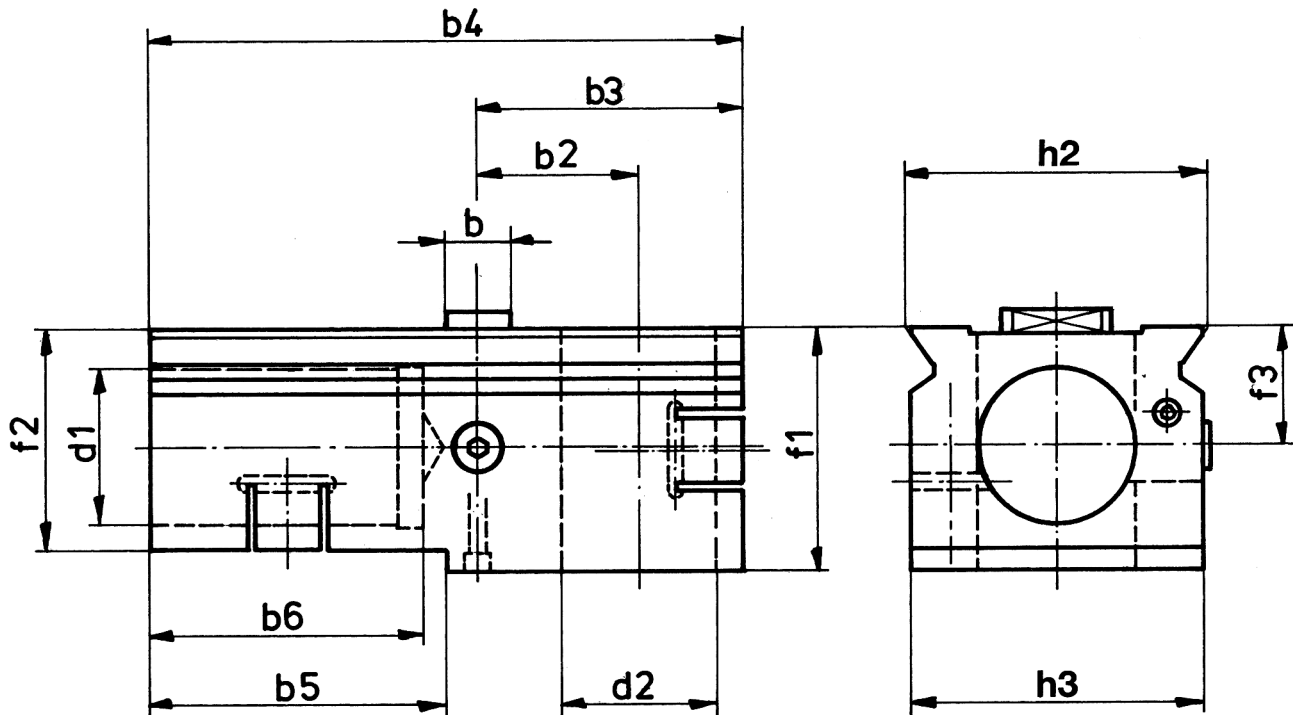

Prisma h ₂	d ₁ H ₇	d ₂ H ₇	h ₃	b	b ₂	b ₃	b ₄	b ₅	b ₆	f ₁	f ₂	f ₃	Bestell-Nummer Part-No. Codification		
	72	40	40	68	20	40	75	175	-	80	70	70	35	325.072.40	
90	50	50	85	25	45	80	210	-	110	80	80	45	325.090.50		
115	60	60	110	25	62,5	102	227	150	105	94	85	45	325.115.60		
140	60	60	135	25	65	105	285	170	105	125	100	60	325.140.60		
140	80	80	135	25	65	120	300	170	150	125	115	60	325.140.80		

Werkzeugkühlung: Kugelspritzdüse. Anschluß für drehbare Rohrverschraubung (soweit techn. möglich).
Coolant: Eyeball unit. Connection for swivelling pipe (where techn. possible).
Refroidissement: Arrosage. Raccord pour tuyan raccordé par vis (autant que possible technique).

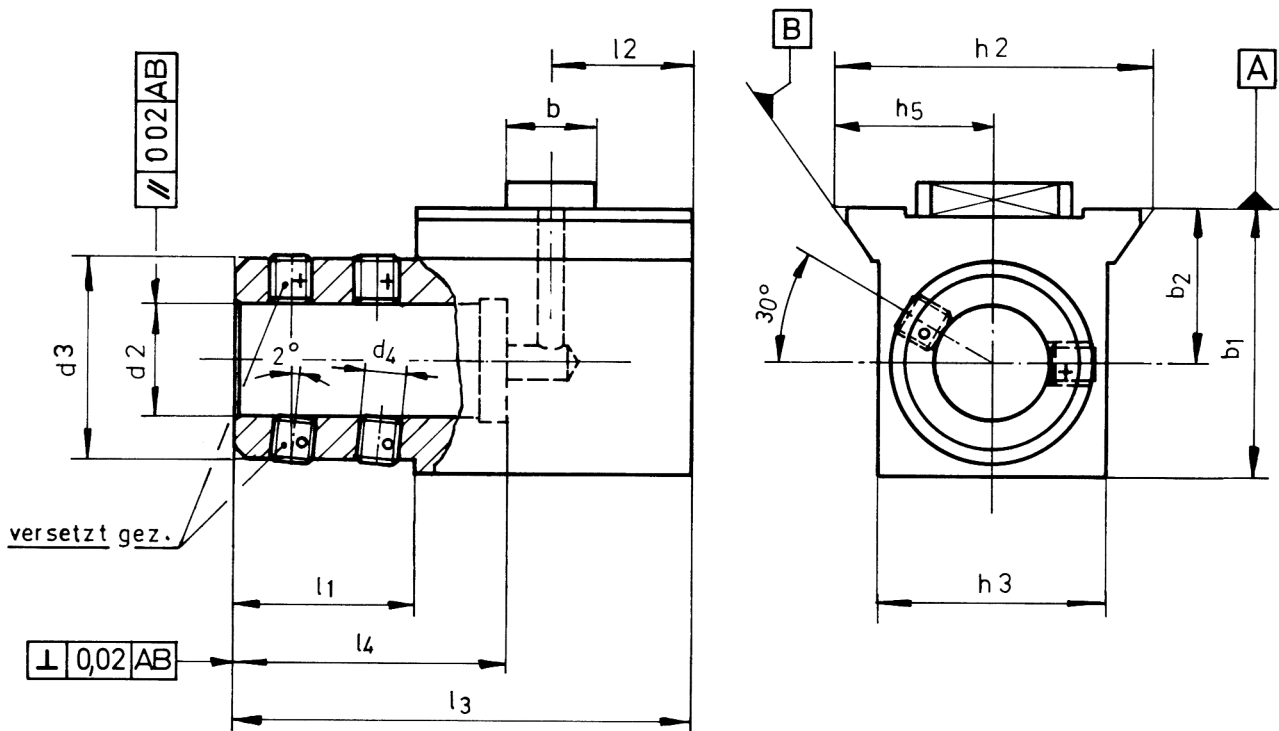

Prisma	d_2 H ₆	d_3	b	b_1	b_2	l_1	l_2	l_3	l_4	h_3	h_5	Bestell-Nummer Part-No. Codification
72	20	45	20	62	35	42	39	110	54	53	36	327.072.20
72	25	52	20	62	35	39	39	110	59	53	36	327.072.25
72	32	65	20	68	35	39	39	110	63	68	36	327.072.32
90	20	45	25	80	45	45	39	138	54	71	45	327.090.20
90	25	52	25	80	45	50	39	138	59	71	45	327.090.25
90	32	65	25	80	45	55	39	138	63	71	45	327.090.32
90	40	72	25	94	45	60	39	138	73	71	45	327.090.40
90	50	82	25	94	45	50	39	138	83	90	45	327.090.50
115	20	45	25	94	45	45	49	148	54	93	57,5	327.115.20
115	25	52	25	94	45	50	49	148	59	93	57,5	327.115.25
115	32	65	25	94	45	55	49	148	63	93	57,5	327.115.32
115	40	72	25	94	45	60	49	148	73	93	57,5	327.115.40
115	50	82	25	94	45	50	49	148	83	93	57,5	327.115.50
140	20	45	25	94	60	45	59	178	54	115	70	327.140.20
140	25	52	25	94	60	50	59	178	59	115	70	327.140.25
140	32	65	25	94	60	55	59	178	63	115	70	327.140.32
140	40	72	25	94	60	60	59	178	73	115	70	327.140.40
140	50	82	25	105	60	72	59	178	83	115	70	327.140.50

»U« Drill Holder with internal coolant channel
Porte Foret pour Foret à Plaquettes

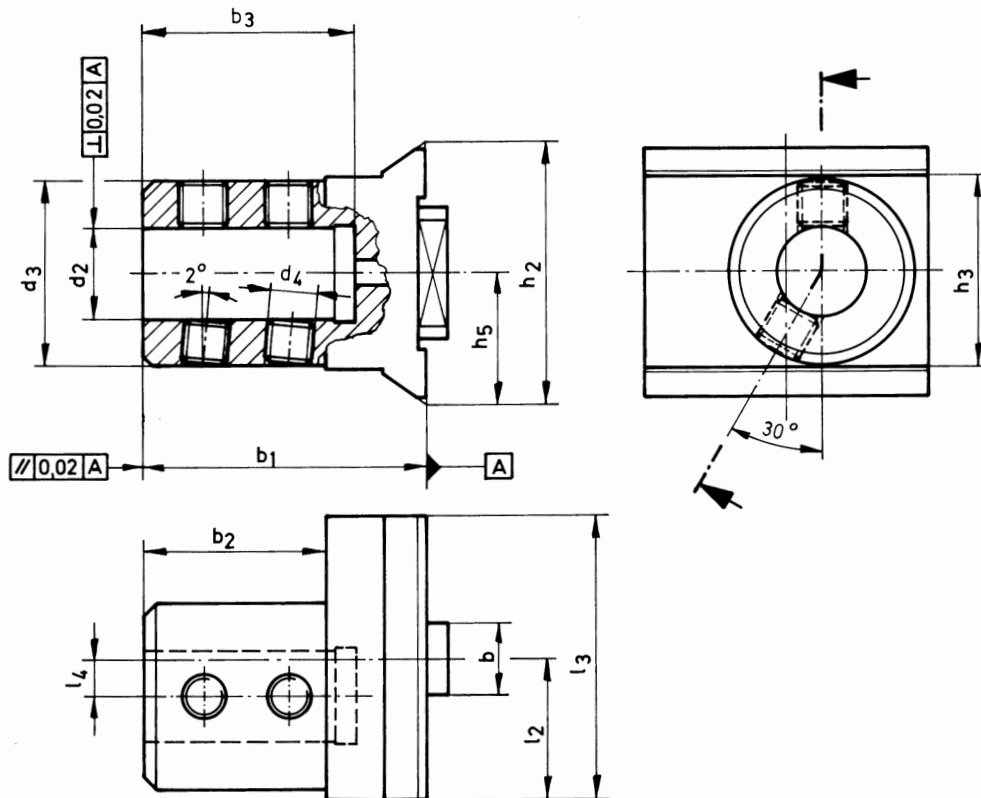

°Prisma	d_2 H ₆	d_3	b	b_1	b_2	b_3		h_3	h_5	l_2	l_3	l_4	Bestell-Nummer Part-No. Codification
72	20	45	20	78	42	54		53	36	39	78	10	329.072.20
72	25	52	20	78	50	59		53	36	39	78	10	329.072.25
72	32	65	20	78	50	63		72	36	39	78	10	329.072.32
90	20	45	25	98	42	54		71	45	49	98	12,5	329.090.20
90	25	52	25	98	50	59		71	45	49	98	12,5	329.090.25
90	32	65	25	98	50	63		71	45	49	98	12,5	329.090.32
90	40	72	25	98	60	73		71	45	49	98	12,5	329.090.40
90	50	82	25	98	70	83		90	45	49	98	12,5	329.090.50
115	20	45	25	98	42	54		93	57,5	49	98	12,5	329.115.20
115	25	52	25	98	50	59		93	57,5	49	98	12,5	329.115.25
115	32	65	25	98	50	63		93	57,5	49	98	12,5	329.115.32
115	40	72	25	98	60	73		93	57,5	49	98	12,5	329.115.40
115	50	82	25	98	70	83		93	57,5	49	98	12,5	329.115.50
140	20	45	25	120	42	54		115	70	59	118	12,5	329.140.20
140	25	52	25	120	50	59		115	70	59	118	12,5	329.140.25
140	32	65	25	120	50	63		115	70	59	118	12,5	329.140.32
140	40	72	25	120	60	73		115	70	59	118	12,5	329.140.40
140	50	82	25	120	70	83		115	70	59	118	12,5	329.140.50

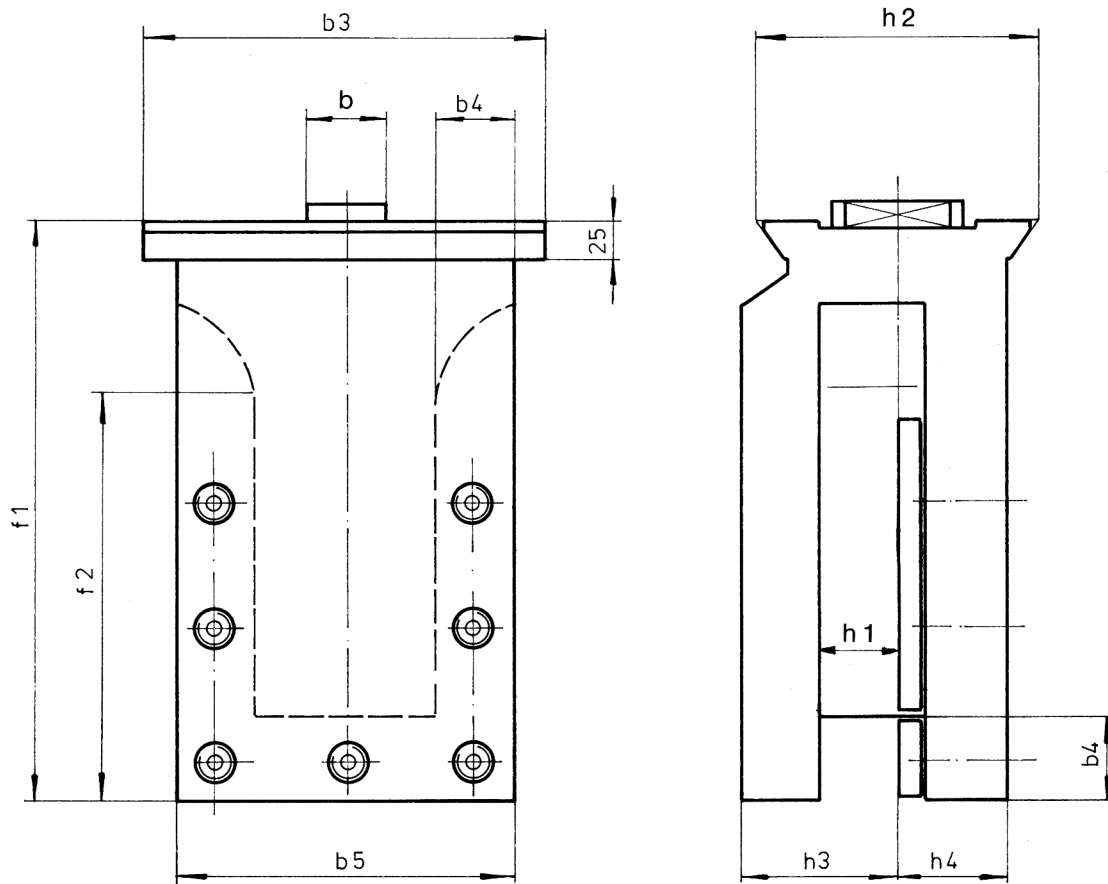

Prisma												Bestell-Nummer Part-No. Codification		
h_2	h_1	h_3	h_4	b	b_3	b_4	b_5	f_1	f_2					
72	20	43	27	20	98	22	70	160	100					330.072.20
90	25	50	35,5	25	108	26	80	200	130					330.090.25
115	32	60	40	25	118	26	98	200	150					330.115.32
140	40	78	57,5	25	144	32	118	240	170					330.140.40

Werkzeugkühlung: Kugelspritzdüse. Anschluß für drehbare Rohrverschraubung (soweit techn. möglich).
Coolant: Eyeball unit. Connection for swivelling pipe (where techn. possible).
Refroidissement: Arrosage. Raccord pour tuyau raccordé par vis (autant que possible technique).

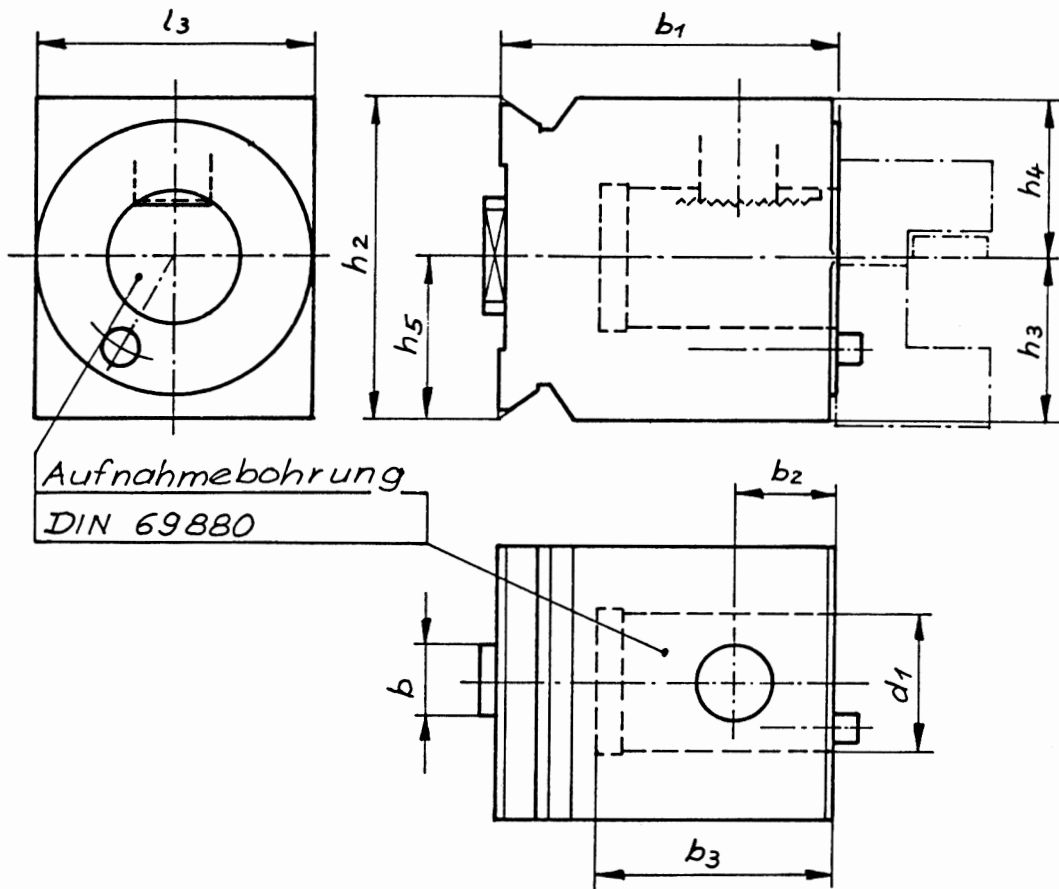

Prisma Weite h₂				d ₁ H ₆	b	b ₁	b ₂	b ₃	L ₃	Bestell-Nummer Codification
	h ₃	h ₄	h ₅							
90	45	45	45	30	25	85	30	60	78	348.090.30.085
90	45	57,5	45	40	25	95	30	70	78	348.090.40.095
90	45	61	45	50	25	110	36	82	98	348.090.50.110
115	46,5	57,5	57,5	40	25	95	30	70	98	348.115.40.095
115	46,5	61	57,5	50	25	110	36	85	98	348.115.50.110
140	57,5	57,5	70	40	25	95	30	70	118	348.140.40.095
140	57,5	61	70	50	25	110	36	85	118	348.140.50.110
140	57,5	76	70	60	25	125	44	100	118	348.140.60.125

Notizen

A large grid of small dots, intended for taking notes. The grid consists of approximately 25 columns and 35 rows of dots, spaced evenly across the page.

Notizen

A large grid of small dots, intended for taking notes. The grid consists of approximately 30 columns and 40 rows of dots, spaced evenly across the page.

Notizen

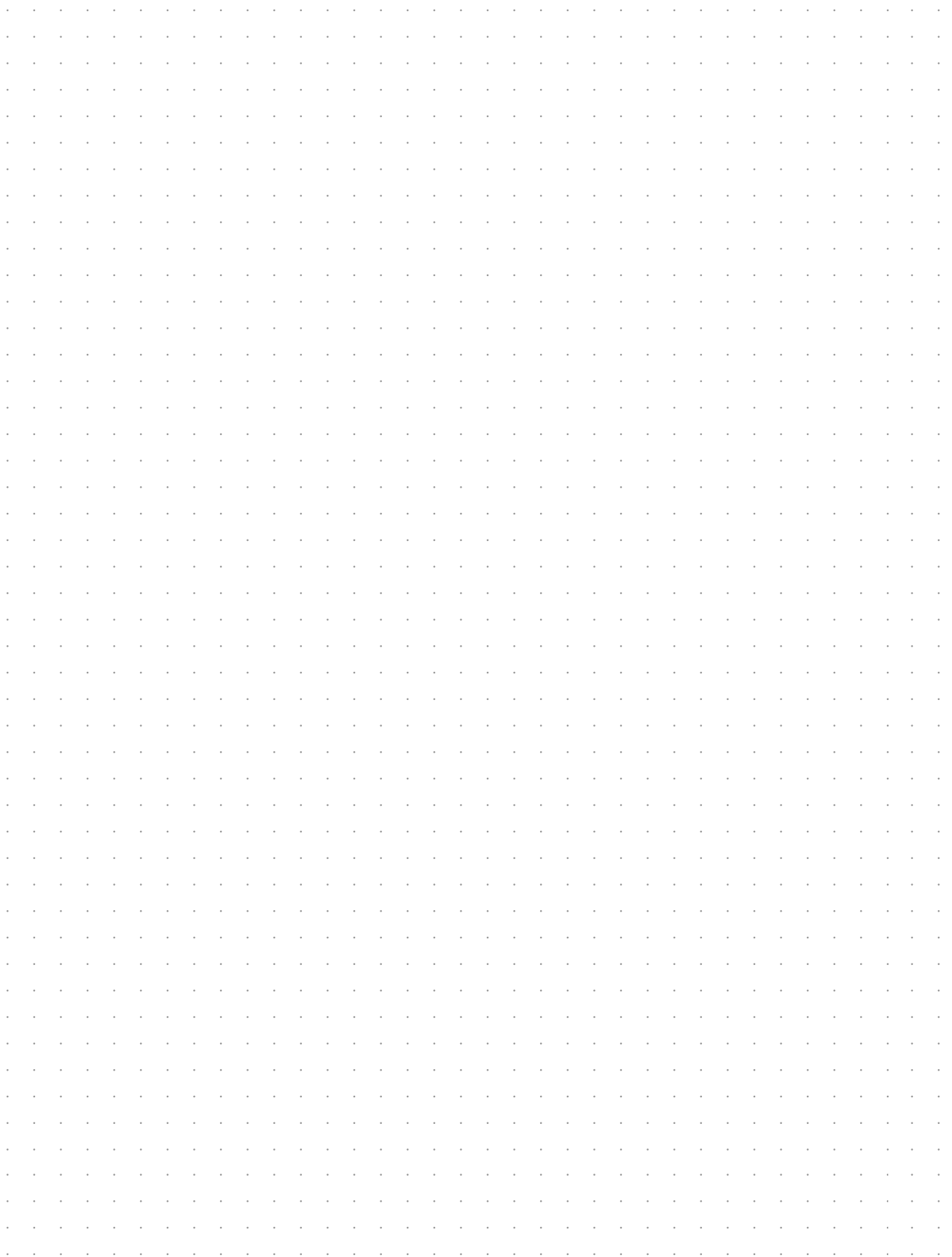

Kataloge und alle technischen Angaben wurden mit größter Sorgfalt zusammengestellt. Trotzdem sind Fehler nicht ganz auszuschließen. Wir weisen deshalb darauf hin, dass weder eine Garantie noch die juristische Verantwortung oder irgendeine Haftung für Folgen, die auf fehlerhafte Angaben zurückgehen, übernommen werden können. Für Mitteilungen eventueller Fehler sind wir dankbar.

Der Katalog ist urheberrechtlich geschützt und bleibt unser Eigentum.

Nachdruck, auch auszugsweise, ist nicht gestattet.

Die bildlichen Darstellungen der Werkzeuge sind unverbindlich.

Änderungen durch Weiterentwicklungen und Irrtum behalten wir uns vor.



Wir sind zertifiziert
nach DIN EN ISO 9001.

We are certified to
DIN EN ISO 9001.

